

# **AIoT9-H510**

## **User's Manual**



Version 1.0

**Disclaimer**

The content of this manual is the intellectual property of the Company, and the copyright belongs to the Company. The ownership of all parts of this product, including accessories and software, is vested in the Company. Without the written permission of the Company, this manual and its any content shall not be imitated, copied, extracted or translated into other languages in any form.

We have carefully prepared this manual with an attitude of being responsible for users, but we do not guarantee that the contents of this manual are completely accurate. This manual is a purely technical document, without any hint or innuendo of third-party content, and does not bear any ambiguity in user understanding caused by typographical errors. In case of any direct or indirect information loss or business termination caused by this manual or all the information about the product mentioned in this manual, the Company and its employees shall not shoulder any responsibility.

Since our products are continuously being improved and updated, the Company reserves the right to amend the contents of this manual without prior notice.

**Copyright statement**

The trademarks mentioned in this manual belong to their legally registered companies.

The product names involved in this manual are for identification purposes only, and their ownership belongs to their manufacturers or brand owners.

## Contents

<b>Chapter 1</b>	<b>General</b>	<b>1</b>
1.1	Packing list	1
1.2	Motherboard specifications	2
1.3	Structure drawing of motherboard	3
1.4	IO interface structure drawing of motherboard	3
1.4.1	AIoT0-H510 IO interface structure drawing (standard version)	3
1.4.2	AIoT0-H510B IO interface structure drawing (high version)	4
1.5	Motherboard layout	4
1.6	IO panel interface	5
1.6.1	AIoT9-H510 IO panel interface (standard version)	5
1.6.2	AIoT9-H510B IO panel interface (high version)	5
<b>Chapter 2</b>	<b>Hardware installation</b>	<b>6</b>
2.1	Install memory	6
2.2	Connect peripherals	7
2.2.1	Serial ATA interface	7
2.2.2	PCIE1/PCIE2/PCI1/PCI2 slot	7
2.2.3	M2-KEYM1 Slot	8
2.2.4	DIMM1/DIMM2/DIMM3/DIMM4 slot	8
<b>Chapter 3</b>	<b>Installation and setup of jumpers &amp; connectors</b>	<b>9</b>
3.1	Setup description of each jumper	9
3.2	Jumper setup	9
3.3	ATXPWR1/PWR12V1 pin interface (standard ATX 24pin+8pin power interface)	10
3.4	CPU_FAN1/SYS_FAN1/SYS_FAN2 pin interface (CPU and system fan interface)	10
3.5	COM1/JCOM2 pin interface (serial port pin)	11
3.6	JCOM3/4/5/6 2.54mm pin interface (RS-232 serial port pin)	11
3.7	LPT1 2.54mm pin interface (printer parallel interface)	12
3.8	J_GPIO1 pin interface (pitch: 2.54mm)	12
3.9	JDVI1 2.00mm pin interface (with one DVI-D interface)	13
3.10	JDEBUG1 pin interface (pitch: 2.0mm)	13
3.11	F_USB2/F_USB1 pin interface	14
3.12	FPANEL1 2.54mm pin interface (power button / power / HDD indicator / reset key)	14
3.13	FPANEL2 2.0mm pin interface (power button / power / HDD indicator / reset key)	15
<b>Chapter 4</b>	<b>BIOS settings</b>	<b>16</b>
4.1	BIOS explanation	16
4.2	BIOS setting	16
4.2.1	Enter the BIOS setup program	16
4.2.2	Control the keys	16
4.3	Main	17
4.4	Advanced	17
4.5	Chipset	24
4.6	Security	25
4.7	Boot	26
4.8	Save & Exit	27
<b>Chapter 5</b>	<b>Install driver</b>	<b>28</b>
<b>Chapter 6</b>	<b>WDT programming guide</b>	<b>29</b>
6.1	WDT control	29
6.1.1	The pseudo-code of Watch Dog is set as follows:	29
6.1.2	Clear watch dog	30
<b>Chapter 7</b>	<b>GPIO programming guide</b>	<b>32</b>
7.1	GPIO control	32
7.1.1	FINTEK 7511 SPEC (see the attached document):	32
<b>Order information</b>		<b>33</b>

**Marking for toxic and harmful substances or elements in this product: .....34**

## Chapter 1 General

### 1.1 Packing list

Thank you for choosing our products.

Please kindly confirm the integrity of the packaging of the motherboard you purchased. If there is any packaging damage or any shortage of accessories, please contact your dealer as soon as possible.

- ★ 1 \* motherboard
- ★ 1 \* driver disc (industrial packaging: 1PCS/box)
- ★ 5 \* COM adapter cable
- ★ 1 \* SATA HDD adapter cable
- ★ 1 \* special I/O buffer



The specifications of the accompanying accessories above are provided for reference only, the actual specifications are subject to the actual product, and the Company reserves the right to modify.

## 1.2 Motherboard specifications

<b>Processor</b>	- Supports all series of LGA1200 packaged Gen10&11 i9/i7/i5/i3 CPU, TDP up to 125W
<b>Chipset</b>	- Intel® H510 chipset, B560 Chipset optional for high version
<b>Memory</b>	- 2 * 288PIN DDR4 UDIMM memory slot for standard version and 4 * 288PIN DDR4 UDIMM memory slot, supports up to 128GB (a single memory slot of 32GB). Supports the memory size DDR4-2133/2400/2666/2933/3200 based on the installed CPU
<b>Display controller</b>	- Intel CPU integrated display controller (different based on the installed CPU)
<b>Display interface</b>	- Four video display output VGA+DP+HDMI+DVI-D, two graphics cards for standard version, and three graphics cards for high configuration
<b>Storage</b>	- 4 * SATA3.0 (when SATA protocol SSD is inserted into M.2, there is no signal from SATA1 ) - 1 * M.2 2242/2280 Key-M, supports SATA/Nvme adaptive function
<b>Audio</b>	- Back-end IO, supports MIC-In, Speaker-Out and Line-In audio interfaces
<b>Network</b>	- Standard Version: 2 * Intel Fast Ethernet ports; High Version: 3 * Intel Fast Ethernet ports: i225 2.5Gb or i219
<b>USB</b>	- Standard version: back-end I/O 4 * USB3.0, 4* USB2.0 back-end 1 * USB2.0 (built-in vertical), 2 * USB2.0 pin - High version: back-end I/O 6 * USB3.0, 2 * USB2.0 back-end 2 * USB2.0 (built-in vertical), 2 * USB2.0 pin
<b>LPT printer port</b>	- 1 * LPT printer port
<b>Serial port</b>	- 6 * serial port (COM1& 2 that support RS232/422/485, and COM3-6 that support RS232)
<b>Keyboard &amp; mouse interface</b>	- 1 * PS/2 2-in-1 interface - 2 * USB with 3-in-1 connector
<b>Digital I/O</b>	- 1 * 16-bit digital I/O, provides power source and ground circuit, +5V level
<b>eSPI bus interface</b>	- 1 * eSPI bus interface (2x6Pin, which can be expanded with up to 4 RS232 or RS422/485 serial ports)
<b>TPM/TCM interface</b>	- Onboard encryption chip SLB9670 (SLB9672), supports TPM2.0 (default)/BOM optional TCM chip
<b>Power source</b>	- ATX power source, supports ATX/AT On/Off mode
<b>Expansion bus</b>	- 1 * PCIe16 slot (Gen 10 CPU supports PCIe3.0, while Gen 11 CPU supports PCIe4.0) - 1 x PCIe x4, 2 x PCI (32bit) - 1 * M.2 2242/2280 Key-M, supports SATA/Nvme adaptive function
<b>Atmospheric conditions of working environment</b>	- Temperature -10°C-60°C; RH 0%-90% (with no condensation); BP 85-105kPa
<b>Atmospheric conditions of storage environment</b>	- Temperature -40°C-85°C; RH 0%-90% (with no condensation); BP 85-105kPa
<b>Watch Dog</b>	- 255-level programmable in the mode of seconds/minutes, supports timeout interrupt or system reset
<b>BIOS</b>	- AMI UEFI BIOS
<b>Operating System</b>	- Win10 x64, Win11 x64, Linux Ubuntu 20.04
<b>PCB size</b>	- 244mm X 244mm

### 1.3 Structure drawing of motherboard

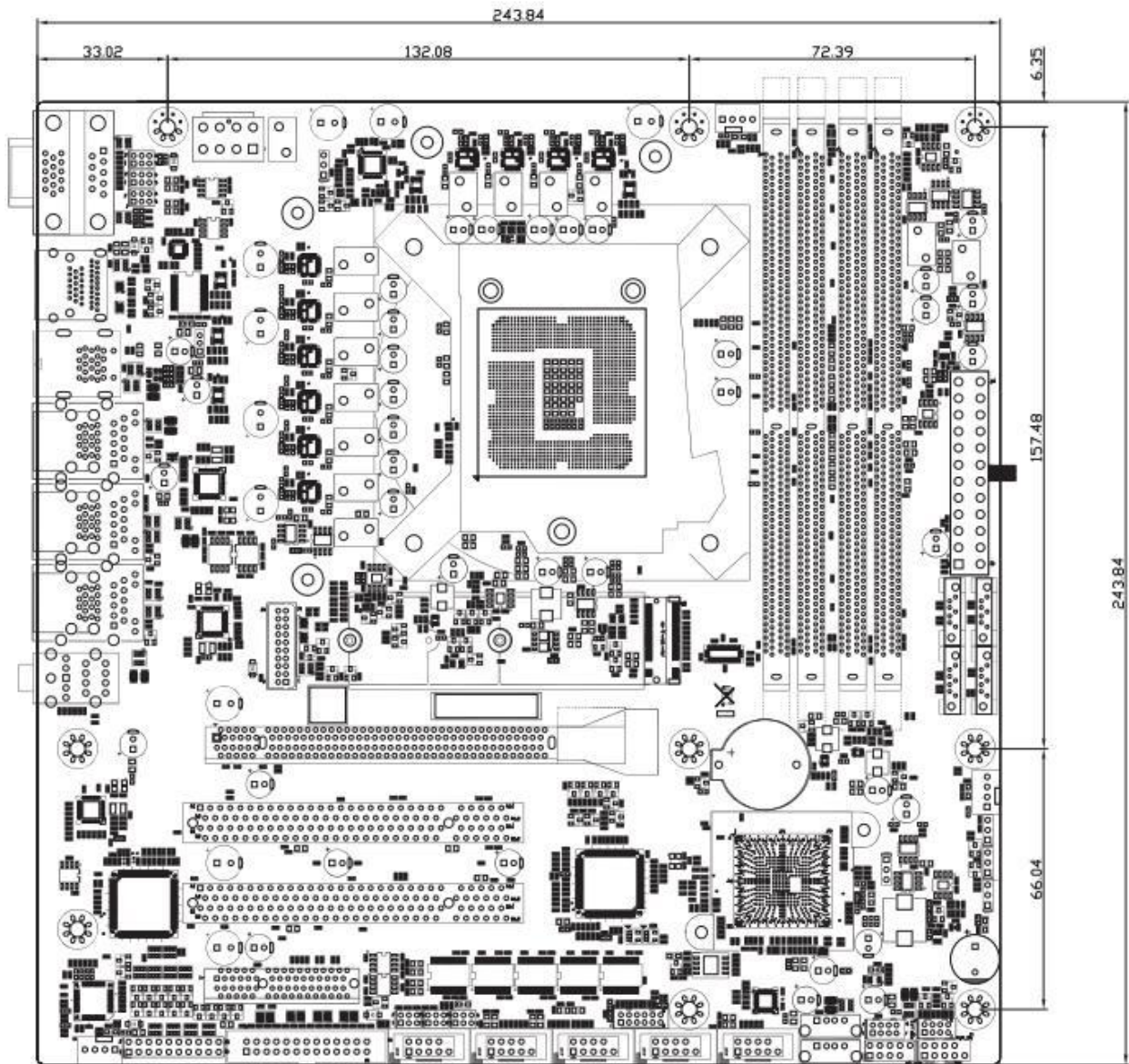

### 1.4 IO interface structure drawing of motherboard

#### 1.4.1 AIoT0-H510 IO interface structure drawing (standard version)

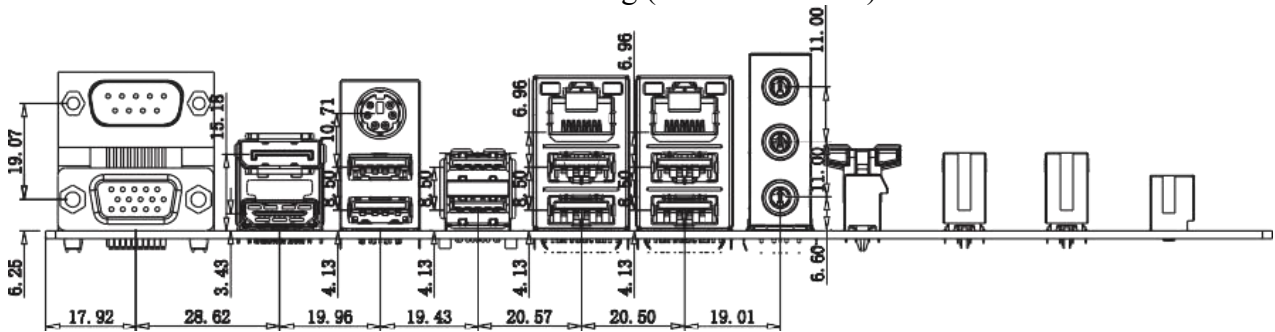



1.4.2 AIoT0-H510B IO interface structure drawing (high version)

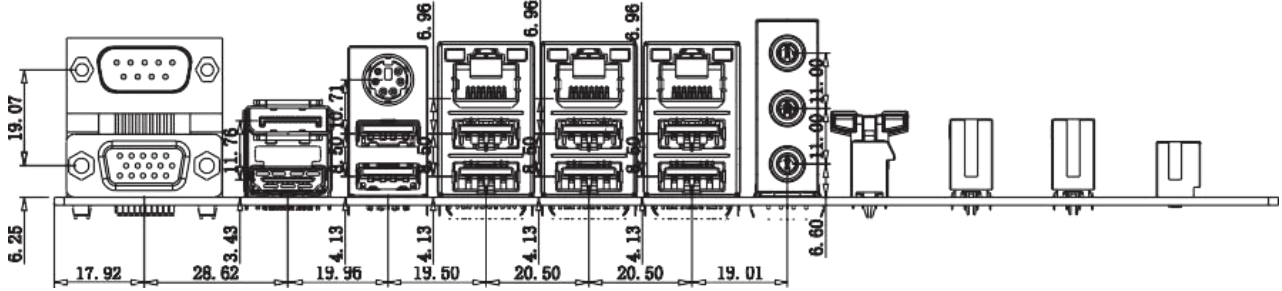

1.5 Motherboard layout

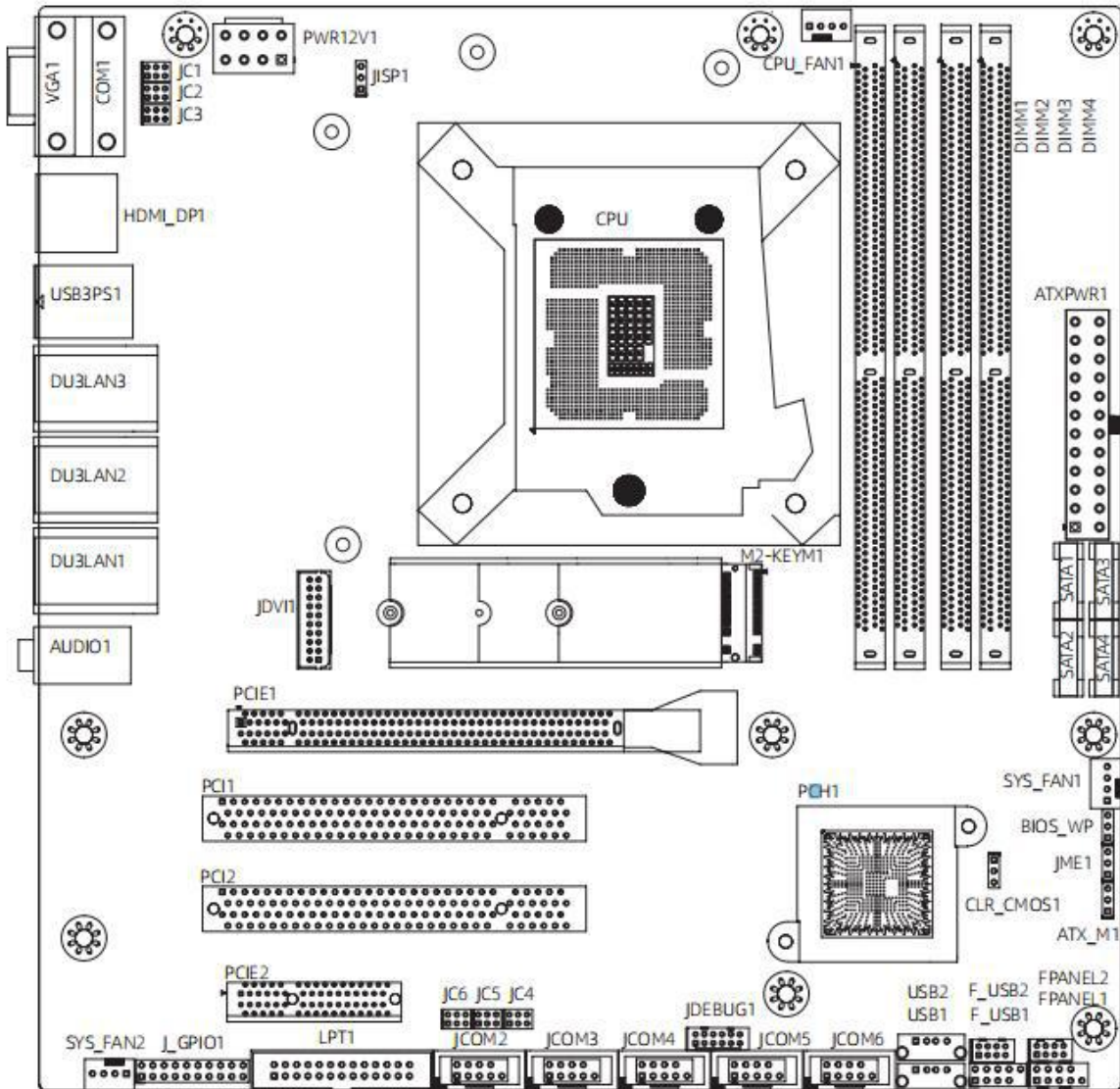

(This image is for reference only, please prevail in kind)



## 1.6 IO panel interface

### 1.6.1 AIoT9-H510 IO panel interface (standard version)

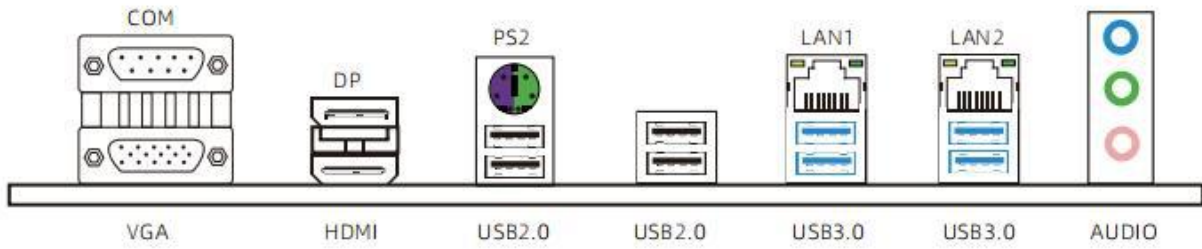

### 1.6.2 AIoT9-H510B IO panel interface (high version)

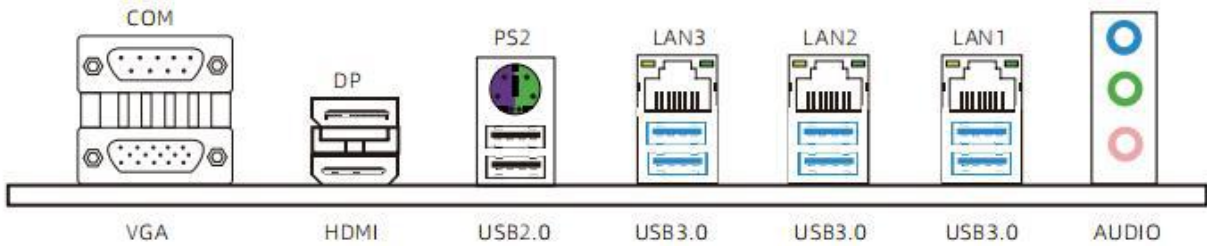

(This image is for reference only, please prevail in kind)

- COM: COM interface
- VGA: VGA display interface
- DP: DP display interface
- HDMI: HDMI display interface
- PS: Keyboard & mouse interface
- USB3.0: USB3.0 interface
- USB2.0: USB2.0 interface
- LAN: RJ45 Ethernet interface
- AUDIO: Audio port

## Chapter 2 Hardware installation

### 2.1 Install memory

Before installing memory, please observe the following warning information:

1. Please make sure that the memory you purchased is compatible with the specifications supported by this motherboard.
2. Before installing or removing memory, please make sure that the computer power is turned off to prevent damage.
3. The memory is designed with fool-proof mechanism. If you insert the memory in the wrong direction, the memory cannot be inserted. In such case, please change the insertion direction immediately.

Install memory:

1. Before installing or removing memory, please turn off the power and unplug the AC power cord.
2. Be careful to hold both edges of the memory module, and do not touch its metal contacts.
3. Align the gold fingers of the memory module with the memory module slot, and pay attention to the convex point of the gold finger socket to the upper slot in the direction.
4. Insert the memory module into the memory slot at an angle of 30°, and then press down the memory module to the sound of “Click”, indicating that the memory has been successfully installed and can be used. (Note: Do not use excessive force when you pressing down the memory module, so as not to damage the memory)
5. To remove the memory module, push the retaining clips on both ends of the DIMM slot outward at the same time, and then remove the memory module.

Memory installation drawing (for reference only):

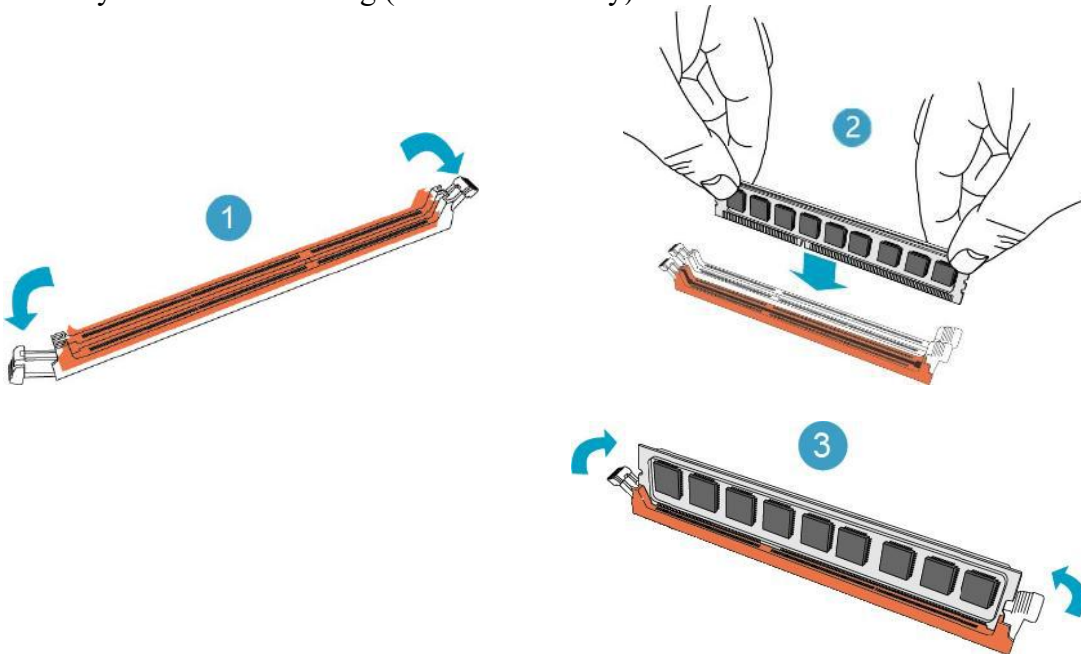

 Note: Static electricity can damage the electronic components of the computer or memory, so before performing the above steps, be sure to briefly touch the grounded metal objects to remove static electricity from your body.

## 2.2 Connect peripherals

### 2.2.1 Serial ATA interface

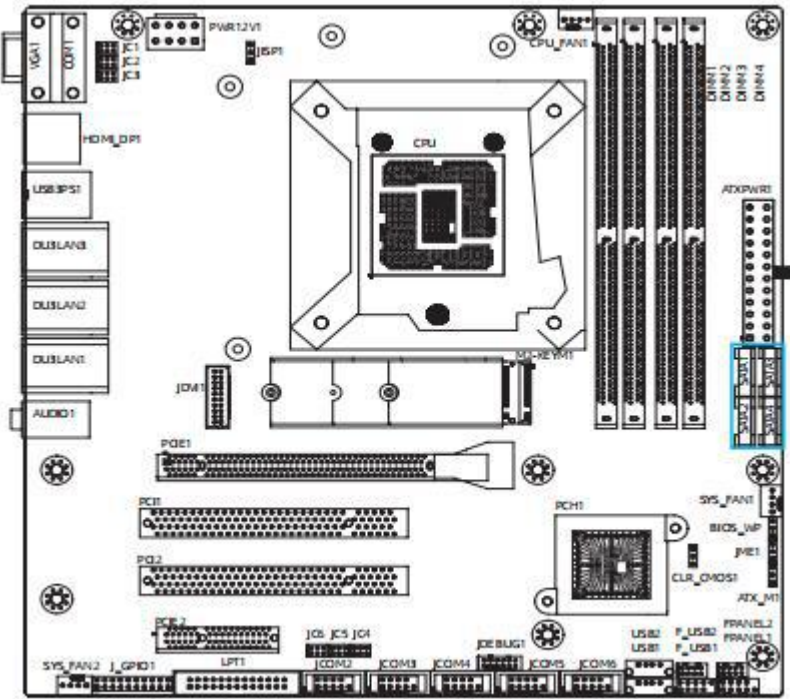

The interface supports the connection to Serial ATA hard disk or other devices that comply with the Serial ATA specification with Serial ATA flat cable.

### 2.2.2 PCIe1/PCIe2/PCI1/PCI2 slot

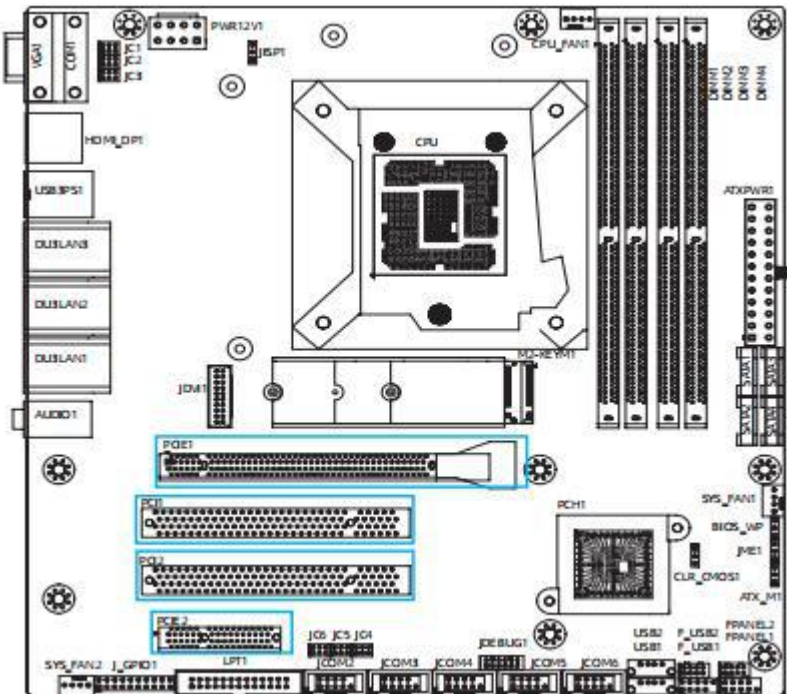

- 1 \* PCIe X16
- 1 \* PCIe X4
- 2 \* PCI

### 2.2.3 M2-KEYM1 Slot

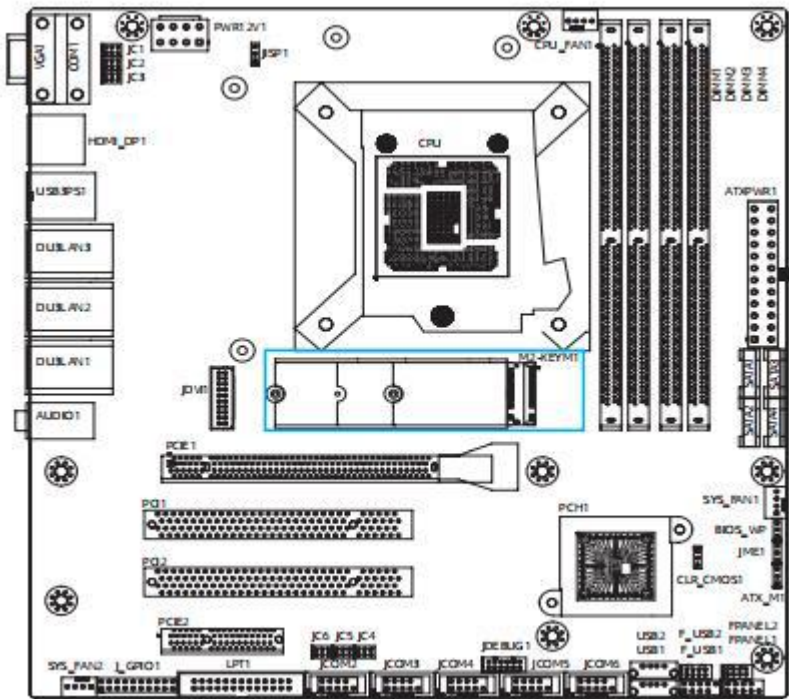

M.2 SATA slot, supports SSD; when installing this card, please insert the card at an angle of 30°, press down to the stud, and then fix it with screws.

### 2.2.4 DIMM1/DIMM2/DIMM3/DIMM4 slot

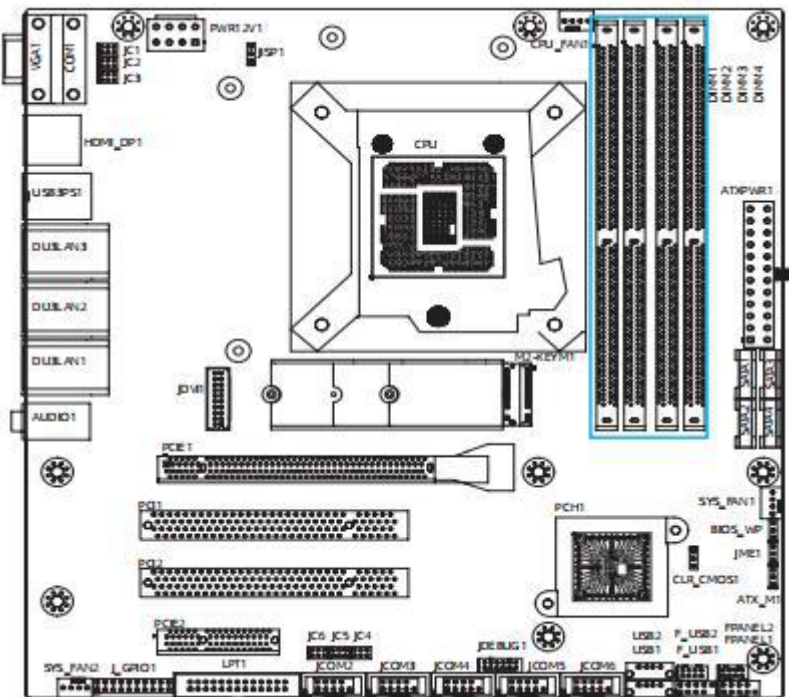

Standard version: 2 \* UDIMM slot; High version: 4 \* UDIMM slot

## Chapter 3 Installation and setup of jumpers & connectors

### 3.1 Setup description of each jumper

2-pin connector: Inserting the jumper cap into two pins will close (short) the connection. Removing the jumper cap or inserting it into other pins (reserved for future expansion) will open the connection.

3-pin connector: The jumper cap can be inserted into pins 1-2 or 2-3 to close (short) the connection.



How to identify the first pin position of a jumper?

1. Please carefully examine the motherboard. Any pin marked with “1” or with white bold line is the first pin position.
2. Examine the solder pads on the back panel. Usually, the square-shaped pad is the first pin.

### 3.2 Jumper setup

JME1 jumper setup (disabled ME, if ME needs to be updated, short circuit 1-2)

Pin	Definition
1-2	Disable ME
2-3	NORMAL

BIOS\_WP jumper setup (short circuit 2-3, and BIOS write protection)

Pin	Definition
1-2	NORMAL
2-3	BIOS WP

COM1 setup

JC1/JC2/JC3 jumper setup

RS232	RS485	RS422
JC1(1-2)	JC1(3-4)	JC1(5-6)
JC2(1-3)	JC2(3-5)	JC2(3-5)
JC2(2-4)	JC2(4-6)	JC2(4-6)
JC3(1-3)		JC3(3-5)
JC3(2-4)		JC3(4-6)

CLR\_COMS1 jumper setup (short circuit 2-3, clear BIOS settings, and restore the default factory settings)

Pin	Definition
1-2	NORMAL
2-3	CLEAR COMS

ATX-M1 jumper setup (1-2: normal mode, press the power button to boot after being electrified; 2-3: automatically boot after being electrified)

Pin	Definition
1-2	ATX Mode
2-3	AT Mode

JCOM2 setup

JC4/JC5/JC6 jumper setup

RS232	RS485	RS422
JC4(1-2)	JC4(3-4)	JC4(5-6)
JC5(1-3)	JC5(3-5)	JC5(3-5)
JC5(2-4)	JC5(4-6)	JC5(4-6)
JC6(1-3)		JC6(3-5)
JC6(2-4)		JC6(4-6)

COM1 and JCOM2 support RS-232/422/485 mode. Three modes can be switched by selecting the above jumper caps.



### 3.3 ATXPWR1/PWR12V1 pin interface (standard ATX 24pin+8pin power interface)

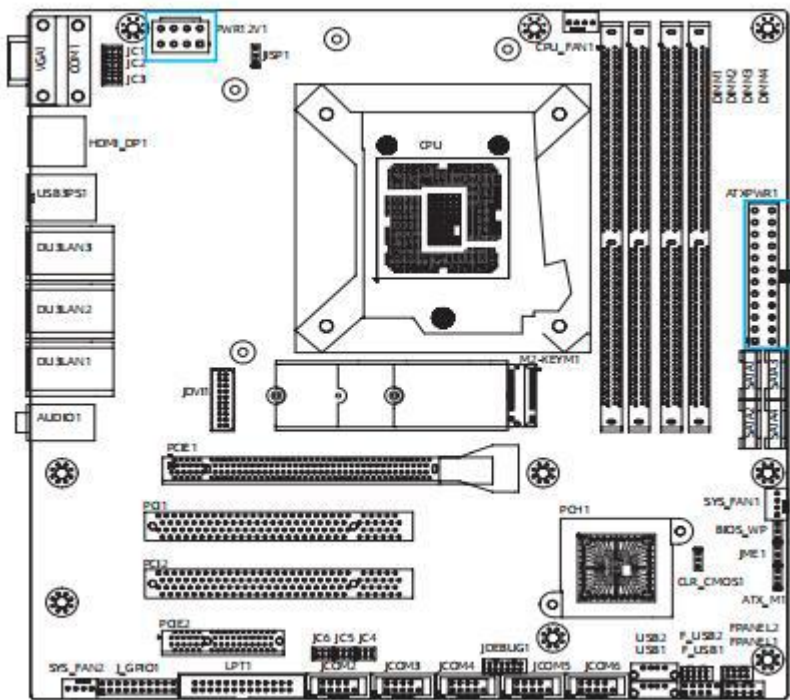

Definition of ATXPWR1 power pin

Pin	Definition of pin	Pin	Definition of pin
1	+3.3V	13	+3.3V
2	+3.3V	14	-12V
3	GND	15	GND
4	+5V	16	PSON#
5	GND	17	GND
6	+5V	18	GND
7	GND	19	GND
8	POK	20	NC
9	5VSB	21	+5V
10	+12V	22	+5V
11	+12V	23	+5V
12	+3.3V	24	GND

Definition of PWR12V1 power pin

Pin	Definition of pin	Pin	Definition of pin
1	GND	5	12V
2	GND	6	12V
3	GND	7	12V
4	GND	8	12V

### 3.4 CPU\_FAN1/SYS\_FAN1/SYS\_FAN2 pin interface (CPU and system fan interface)

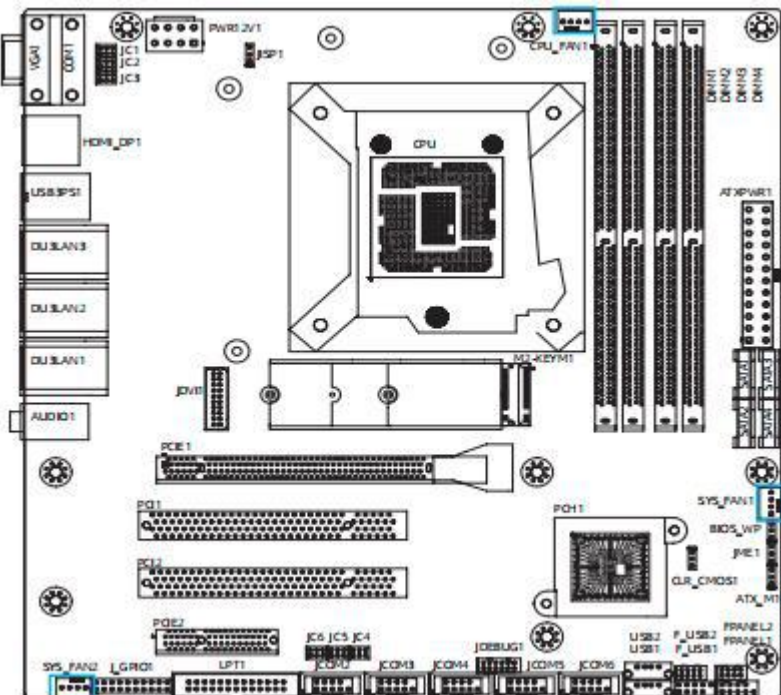

Pin	Definition of pin
1	GND
2	+12V
3	FAN_IN
4	FAN_OUT

### 3.5 COM1/JCOM2 pin interface (serial port pin)

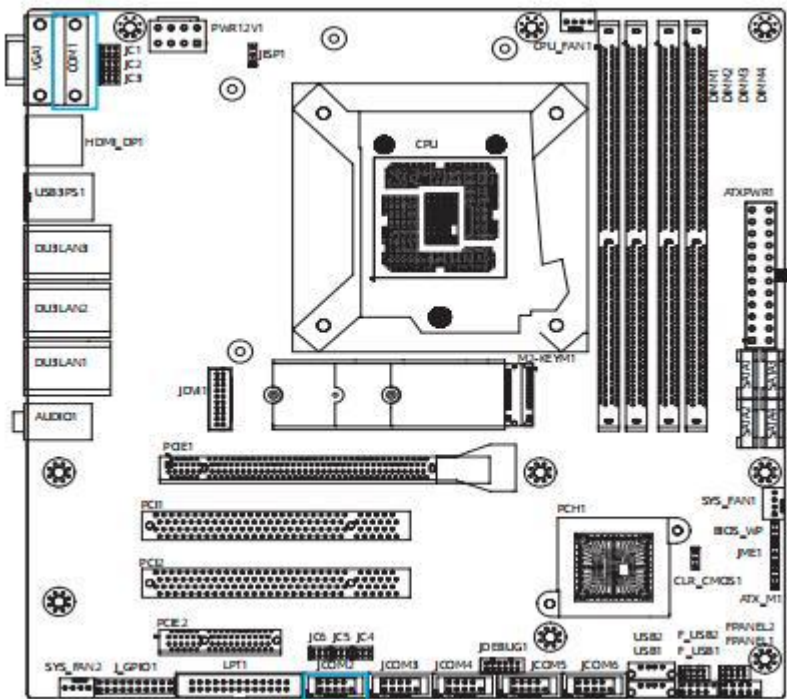

Pin	RS232	RS422	RS485
	Definition of pin	Definition of pin	Definition of pin
1	DCD#	TX-	DATA-
2	RXD	TX+	DATA+
3	TXD	RX+	NC
4	DTR#	RX-	NC
5	GND	GND	GND
6	DSR#	NC	NC
7	RTS#	NC	NC
8	CTS#	NC	NC
9	RI#	NC	NC

Note: COM1, and JCOM2 serial ports need to be switched among RS232, RS422 or RS485 through the jumper setup. Users can refer to “3.2 Jumper setup” for its jumper setup.

### 3.6 JCOM3/4/5/6 2.54mm pin interface (RS-232 serial port pin)

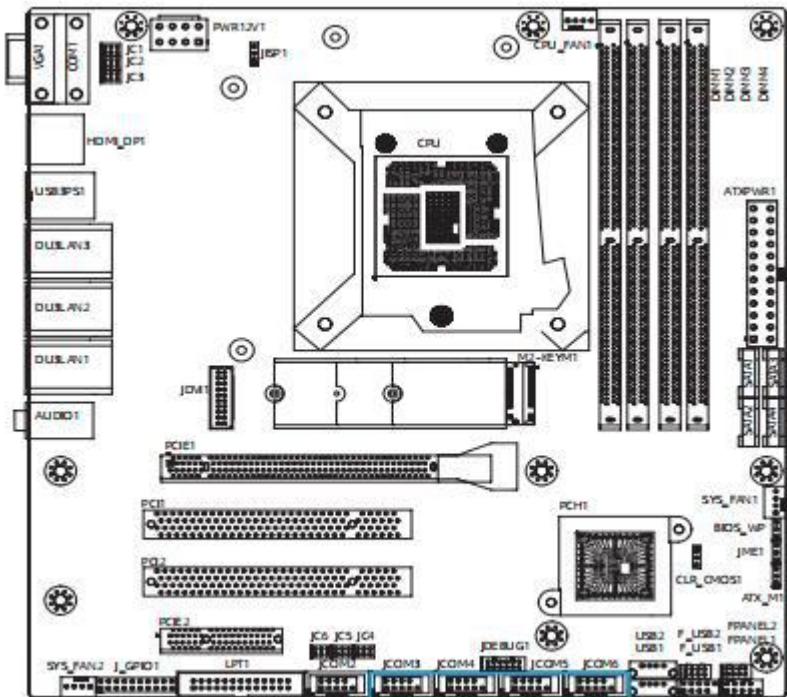

Pin	Definition of pin	Pin	Definition of pin
1	DCD	2	RXD
3	TXD	4	DTR
5	GND	6	DSR
7	RTS	8	CTS
9	RI		



### 3.7 LPT1 2.54mm pin interface (printer parallel interface)

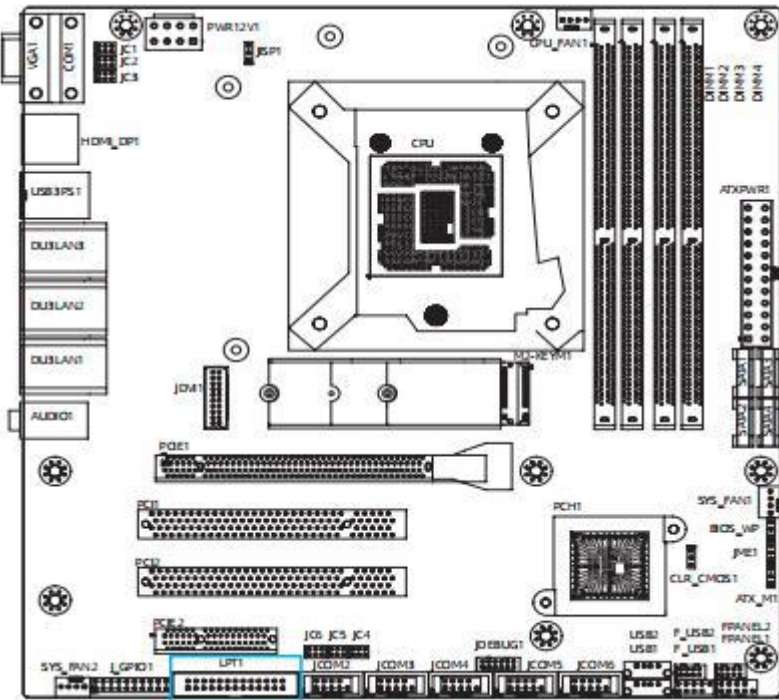

Pin	Definition of pin	Pin	Definition of pin
1	LPT_STB	2	LPT_AFD
3	LPT_PD0	4	LPT_ERR
5	LPT_PD1	6	LPT_INIT
7	LPT_PD2	8	LPT_SLIN
9	LPT_PD3	10	GND
11	LPT_PD4	12	GND
13	LPT_PD5	14	GND
15	LPT_PD6	16	GND
17	LPT_PD7	18	GND
19	LPT_ACK	20	GND
21	LPT_BUSY	22	GND
23	LPT_PE	24	GND
25	LPT_SLCT	26	NC

### 3.8 J\_GPIO1 pin interface (pitch: 2.54mm)

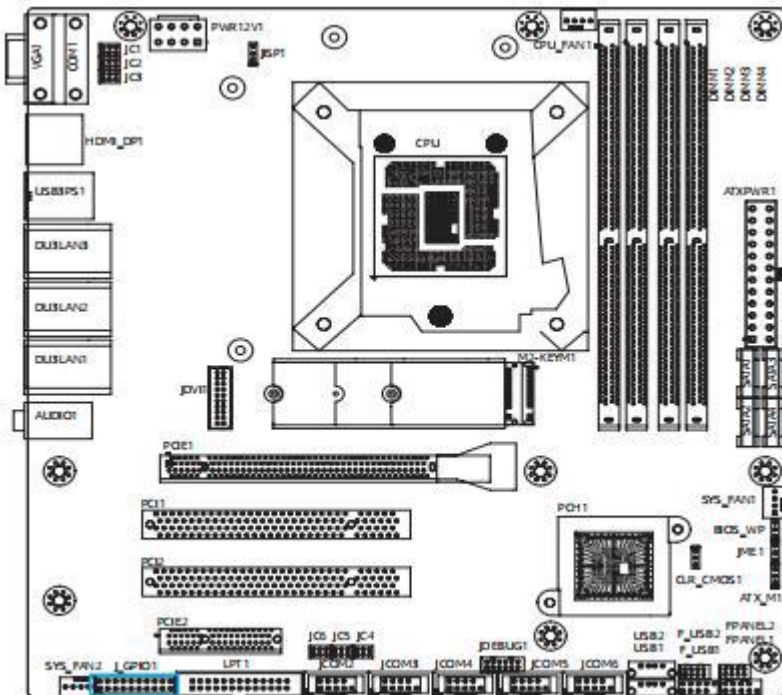

Pin	Definition of pin	Pin	Definition of pin
1	5V	2	GND
3	GPIO1	4	GPIO2
5	GPIO3	6	GPIO4
7	GPIO5	8	GPIO6
9	GPIO7	10	GPIO8
11	GPIO9	12	GPIO10
13	GPIO11	14	GPIO12
15	GPIO13	16	GPIO14
17	GPIO15	18	GPIO16
19	GND	20	5V

### 3.9 JDVII 2.00mm pin interface (with one DVI-D interface)

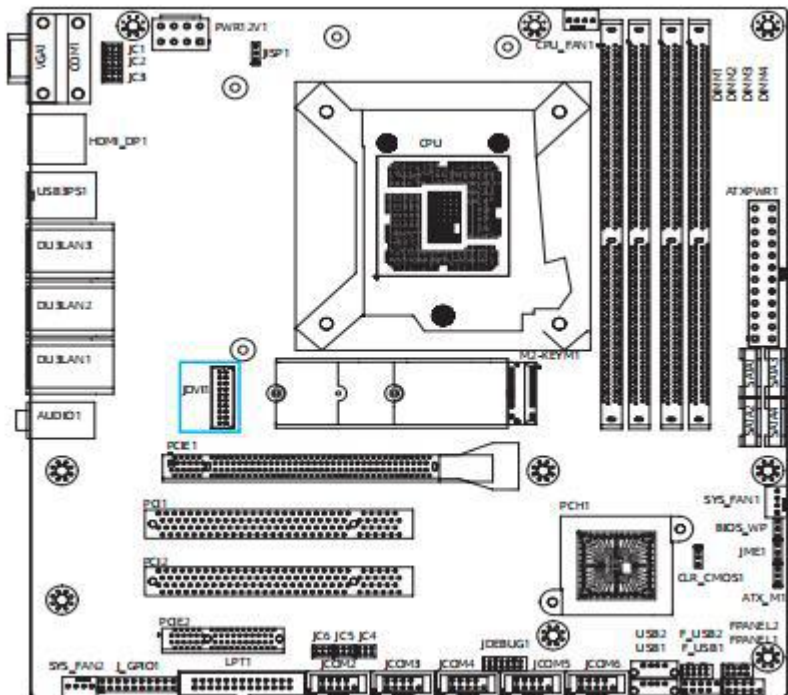

Pin	Definition of pin	Pin	Definition of pin
1	GND5	2	GND1
3	DDDCCLK	4	DDCDATA
5	HPDET	6	+5V
7	CLK-	8	CLK+
9	GND6	10	GND2
11	DATA0+	12	DATA0-
13	GND7	14	GND3
15	DATA1+	16	DATA1-
17	GND8	18	GND4
19	DATA2+	20	DATA2-

### 3.10 JDEBUG1 pin interface (pitch: 2.0mm)

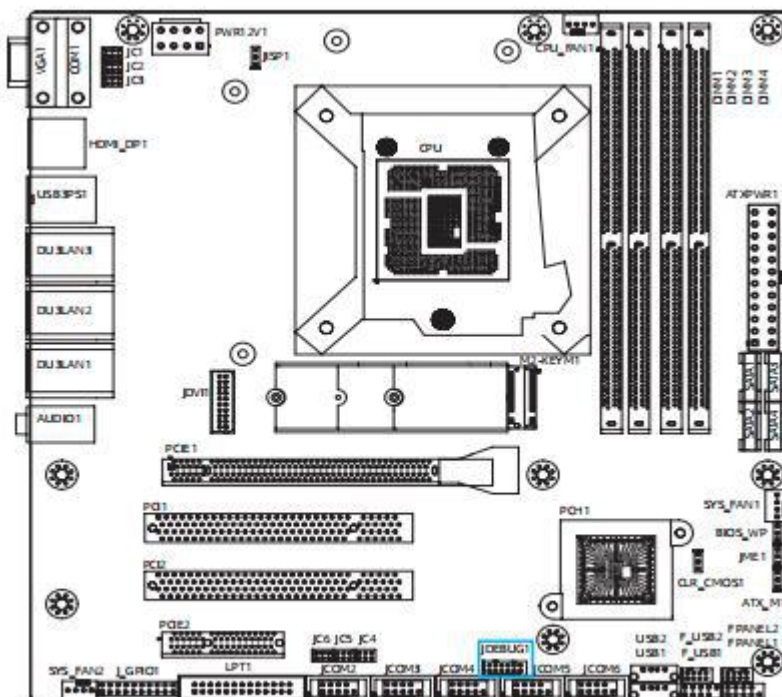

Pin	Definition of pin	Pin	Definition of pin
1	+3.3V	2	GND
3	ESPI_IO0	4	ESPI_CS
5	ESPI_IO1	6	ESPI_CLK
7	ESPI_IO2	8	ESPI_RST
9	ESPI_IO3	10	PLTRST
11	ESPI_ALERT	12	+5V

Provides ESPI signal, the interface can be expanded with serial port modules

### 3.11 F\_USB2/F\_USB1 pin interface

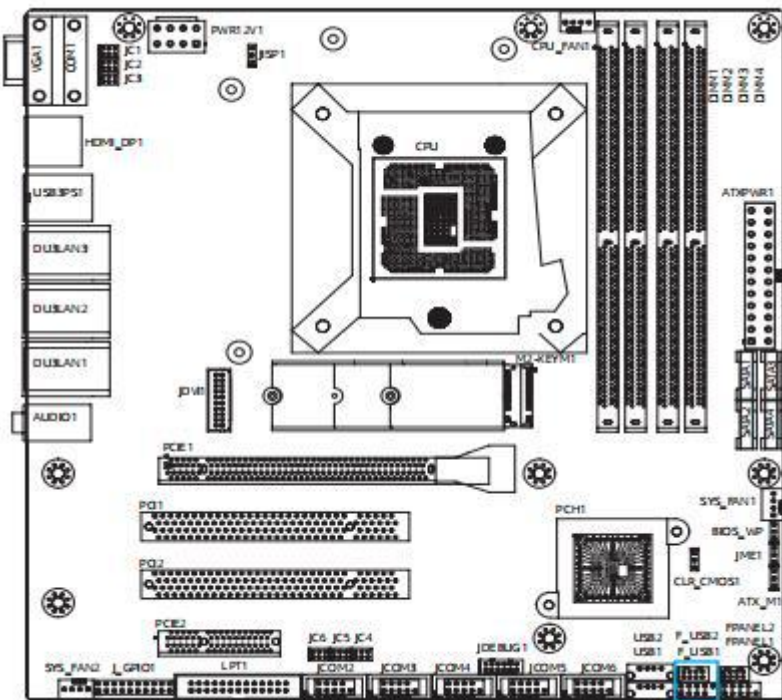

F\_USB2 2.0 mm pin interface

Pin	Definition of pin	Pin	Definition of pin
1	5V	2	5V
3	D1-	4	D2-
5	D1+	6	D2+
7	GND	8	GND

F\_USB1 2.54 mm pin interface

Pin	Definition of pin	Pin	Definition of pin
1	5V	2	5V
3	D1-	4	D2-
5	D1+	6	D2+
7	GND	8	GND
		10	NC

Standard version: 1 \* USB2.0, USB1 for built-in vertical; High version: 2 \* USB2.0, USB1 and USB2 for built-in vertical

### 3.12 FPANEL1 2.54mm pin interface (power button / power / HDD indicator / reset key)

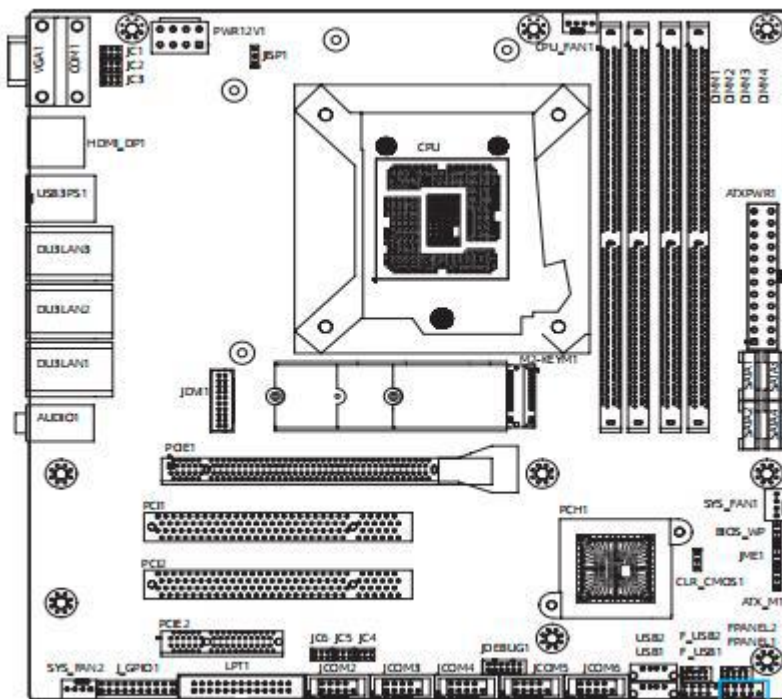

Pin	Definition of pin	Pin	Definition of pin
1	HDD_LED+	2	PWRLED+
3	HDD_LED-	4	PWRLED-
5	GND	6	PWR_SW
7	SYS_RST	8	GND
9	NC		



### 3.13 FPANEL2 2.0mm pin interface (power button / power / HDD indicator / reset key)

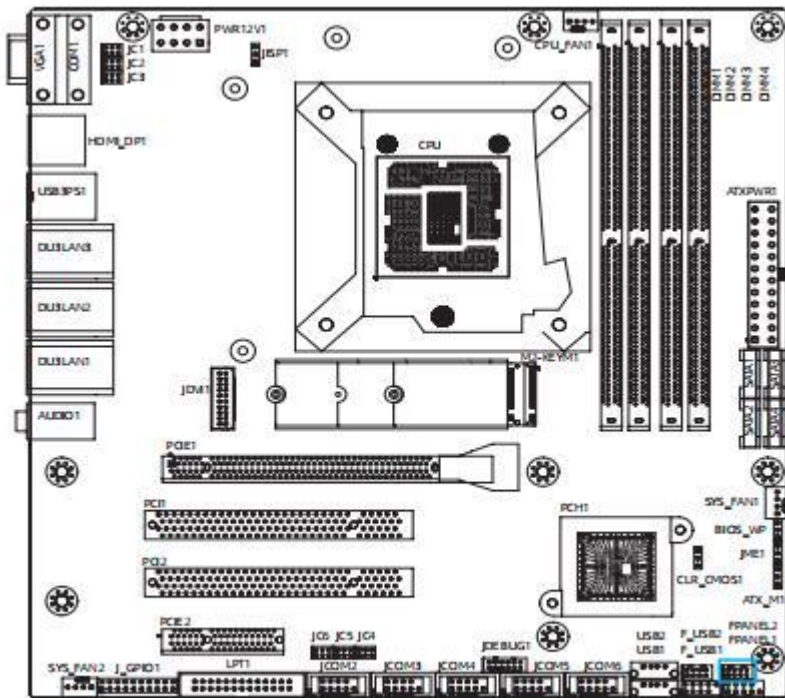

Pin	Definition of pin	Pin	Definition of pin
1	PWR_ON	2	GND
3	GND	4	FPREST_N
5	HDDLED-	6	HDDLED+
7	PWRLED-	8	PWRLED+

## Chapter 4 BIOS settings

### 4.1 BIOS explanation

This motherboard uses AMI BIOS. The full name of BIOS is Basic Input Output System. It is stored in a ROM (Read-Only Memory) chip on the computer motherboard. When you turn on your computer, BIOS is the first program to run. It mainly has the following functions:

- a. Initialize your computer and detect hardware, this process is called POST (Power On Self Test).
- b. Load and run the operating system.
- c. Provide the lowest and most basic control over your computer hardware.
- d. Manage your computer through SETUP.

The modified BIOS data will be stored in a battery-maintained CMOS RAM, and the stored data area will not be lost when the power is cut off. Generally, there is no need to modify the BIOS when the system is running normally. If the CMOS data is lost due to other reasons, the BIOS value must be reset.

### 4.2 BIOS setting

This chapter provides information about the BIOS Setup program, allowing users to configure and optimize system settings by themselves. Some items in the BIOS that have not been explained too much are not commonly used items. It is recommended to keep the default settings and not change them arbitrarily before fully understanding their functions.

You need to run the SETUP program under the following cases:

- a. An error message appears on the screen during the system self-test, and it is required to enter the SETUP program;
- b. You want to change the factory default settings according to customer characteristics.

Note: Since the BIOS version of the motherboard is constantly being upgraded, the description of the BIOS in this manual is for reference only. We do not guarantee that the relevant content in this manual is consistent with the information you have obtained.

#### 4.2.1 Enter the BIOS setup program

Turn on the power or restart the system, you can see the following information on the self-test screen, press <DEL> key to enter the BIOS setup program.

Press <Delete> to enter SETUP

Press <F11> to enter Boot Menu

#### 4.2.2 Control the keys

You can use the arrow key to move the highlighted option, and press <Enter> key to select, <F1> key for help, and <Esc> key to exit. The following table will detail how to use the keyboard to boot the program settings of system.

Control key	Functional description
← / →	Move the left and right arrows to select the screen
↑ / ↓	Move the up and down arrows to select the items up and down.
+ / -	Increase/decrease value or change option
<Enter>	Select this option to enter the sub-menu

<ESC>	Return to the main screen, or end the CMOS SETUP program from the main screen
<F1>	Show the related help
<F7>	Previous settings
<F9>	Load the optimized settings
<F10>	Save the modified CMOS settings and reboot

### 4.3 Main



- **BIOS Information (BIOS related information)**
- **System Language (system language setting)**  
Set the system language of the computer in the format of <Chinese> <English>.
- **System Date (system date setting)**  
Set the date of the computer in the format of “month/day/year”.
- **System Time (system time setting)**  
Time format is <hour><minute><second>.

### 4.4 Advanced

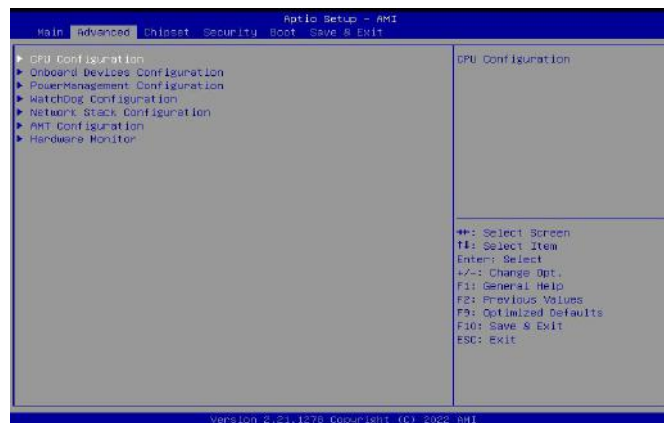

- ▶ **CPU Configuration Press <Enter> key to enter the sub-menu**



- **CPU Configuration**  
Set the central processing unit.
- Press <Esc> key to return to “Advanced” main menu
- ▶ **Onboard Devices Configuration** Press <Enter> key to enter the sub-menu



- **Onboard Audio**  
Enable or disable audio interface of motherboard.  
Options: Enabled, Disabled.
- **PCH LAN Controller (I219)**  
Set the PCH LAN controller.  
Options: Enabled, Disabled.
- **Onboard LAN (I226\_LM)**  
Enable or disable onboard network board.  
Options: Enabled, Disabled.
- **Onboard LAN (I226\_LV)**  
Enable or disable onboard network board.  
Options: Enabled, Disabled.
- **I225 PXE ROM**  
Enable or disable pre-boot execution environment.  
Options: Enabled, Disabled.
- **PS/2 Port Setting**  
Set the keyboard & mouse.  
Options: Auto, Keyboard, Mouse.
- **BIOS Write Protect**



BIOS write protection.

Options: Enabled, Disabled.

- **Me Lock**

Lock the ME access permission.

Options: Enabled, Disabled.

- Press <Esc> key to return to “Advanced” main menu

► **NCT6126D Super IO Configuration Press <Enter> key to enter the sub-menu**

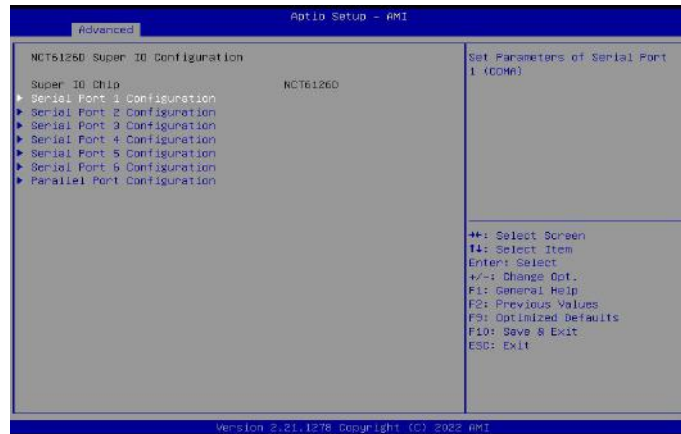

- **Serial Port1/2/3/4/5/6 Configuration**

Set the serial ports.

- **Parallel Port Configuration**

Configure the parallel port.

Press <Esc> key to return to “Advanced” main menu

► **NCT5114DSEC Super IO Configuration**

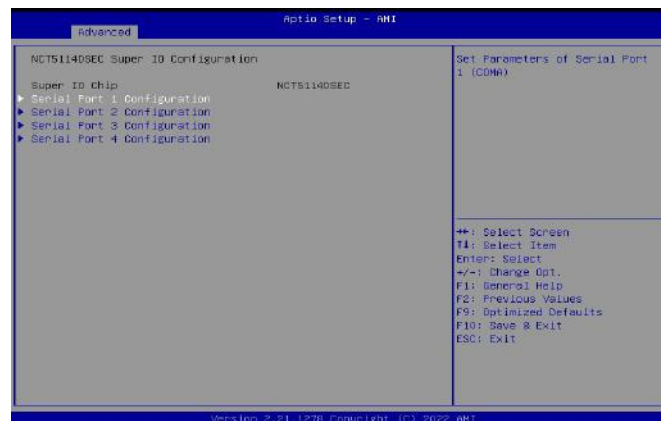

- **Serial Port1/2/3/4 Configuration**

Set the serial ports.

- Press <Esc> key to return to “Advanced” main menu

► **CSM Configuration**



- **CSM Support**  
Enable or disable CSM support.  
Options: Enabled, Disabled.
- Press <Esc> key to return to “Advanced” main menu
- ▶ **SATA Configuration** Press <Enter> key to enter the sub-menu



- **SATA Controller**  
Enable or disable SATA controller.  
Options: Enabled, Disabled.
- **SATA Mode Selection**  
Select SATA mode.  
Options: AHCI, Raid.
- Press <Esc> key to return to “Advanced” main menu
- ▶ **NVMe Configuration** Press <Enter> key to enter the sub-menu



- **No NVME Device Found**  
There is no NVME device found.

Press <Esc> key to return to “Advanced” main menu

► **Trusted Computing** Press <Enter> key to enter the sub-menu

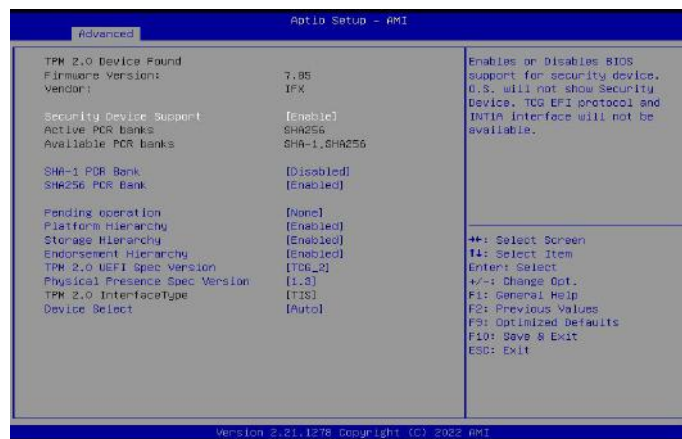

- **Security Device Support**  
Set the BIOS support of security device.  
Options: Enabled, Disabled.
- **SHA-1 PCR Bank**  
Enable or disable SHA-1 PCR Bank.  
Options: Enabled, Disabled.
- **SHA256 PCR Bank**  
Enable or disable SHA256 PCR Bank.  
Options: Enabled, Disabled.
- **Pending operation**  
Set the pending operation.  
Options: None, TPM Clear.
- **Platform Hierarchy**  
Enable or disable the platform hierarchy.  
Options: Enabled, Disabled.
- **Storage Hierarchy**  
Enable or disable the storage hierarchy.  
Options: Enabled, Disabled.
- **Endorsement Hierarchy**

Enable or disable the endorsement hierarchy.

Options: Enabled, Disabled.

- **TPM 2.0 UEFI Spec Version**

Enable the specification version of TPM2.0 in UEFI.

Options: TCG\_1\_2,TCG\_2.

- **Physical Presence Spec Version**

Set the physical presence specification version.

Options: 1.2,1.3.

- **Device Select**

Set the device selection.

Options: TPM 1.2,TPM 2.0,Auto.

- Press <Esc> key to return to “Advanced” main menu

► **PTT Configuration**

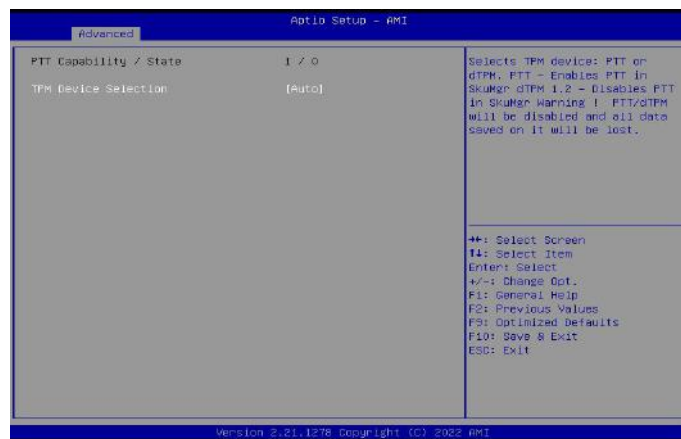

- **TPM Device Selection**

Select the TPM device.

Options: Auto, dTPM, PTT.

Press <Esc> key to return to “Advanced” main menu

► **Power Management Configuration Press <Enter> key to enter the sub-menu**



- **Restore AC Power Loss**

Set the status of AC power.  
Options: Power Off, Power On, Last State.

- **Wake on LAN**  
Enable or disable LAN.  
Options: Enabled, Disabled.
  - **PS/2 Keyboard Wake Up**  
Enable or disable PS/ 2 keyboard.  
Options: Enabled, Disabled.
  - **PS/2 Mouse Wake Up**  
Enable or disable PS/ 2 mouse.  
Options: Enabled, Disabled.
  - **RTC Wake system from S5**  
Set the RTC wake-up.  
Options: Disabled, Fixed Time, Dynamic Time.
- Press <Esc> key to return to “Advanced” main menu

► **WatchDog Configuration Press <Enter> key to enter the sub-menu**



- **WatchDog Support**  
Enable or disable watch dog.  
Options: Enabled, Disabled.
- Press <Esc> key to return to “Advanced” main menu

► **Network Stack Configuration Press <Enter> key to enter the sub-menu.**

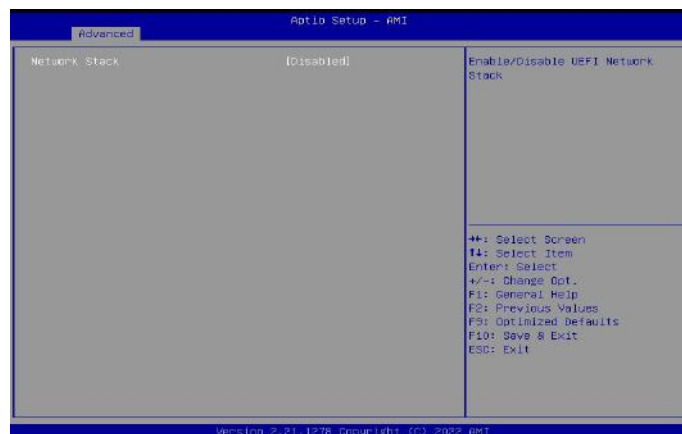

- **Network Stack**  
Enable or disable network protocol.  
Options: Enabled, Disabled.

▶ **AMT Configuration** Press <Enter> key to enter the sub-menu



- **USB Provisioning of AMT**  
Enable or disable AMT USB provisioning.  
Options: Enabled, Disabled.
- Press <Esc> key to return to “Advanced” main menu

▶ **Hardware Monitor** Press <Enter> key to enter the sub-menu

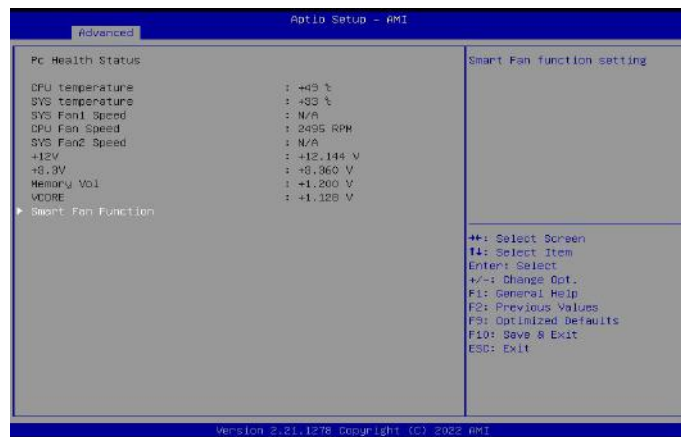

- **Smart Fan Function**  
Smart fan speed control.
- Press <Esc> key to return to “Advanced” main menu

#### 4.5 Chipset



- **Primary Display**  
Display the default settings of onboard integrated and independent graphics.  
Options: Auto, Enabled, Disabled.
- **Above 4GB MMIO BIOS assignment**  
Enable or disable 4GB MMIO BIOS assignment.  
Options: Enabled, Disabled.
- **DVMT Total Gfx Mem**  
Set the memory size of DVMT.  
Options: 256M,128M,MAX.
- Press <Esc> key to return to “Chipset” main menu

► **Memory Configuration**

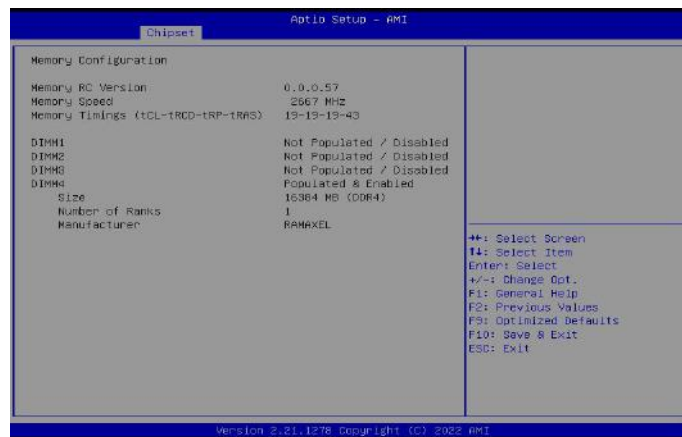

- **Memory Configuration**  
Set the memory.
- Press <Esc> key to return to “Chipset” main menu

4.6 Security





- **Administrator Password**

If this option is used to set the system administrator password, there are the following steps:

1. Select the Administrator Password setting item, and press <Enter> key.
2. Enter 3 to 20 character or numeric passwords to be set in the “Create New Password” dialog box. After the input is completed, press <Enter> key, and then enter the password again to confirm that the password is correct in the “Confirm Password” dialog box. If the screen shows “Invalid Password!”, it indicates that the passwords entered twice are different, please enter them again. To delete the system administrator password, please select “Administrator Password”, and complete deletion when the “Create New Password” dialog box appears after entering the old password in the “Enter Current Password” dialog box and pressing <Enter>.

- **User Password**

Set the user password, the setting steps are the same as that of “Administrator Password”.

- **Password check**

Set the password check.

Options: Setup, Setup & Post.

## 4.7 Boot

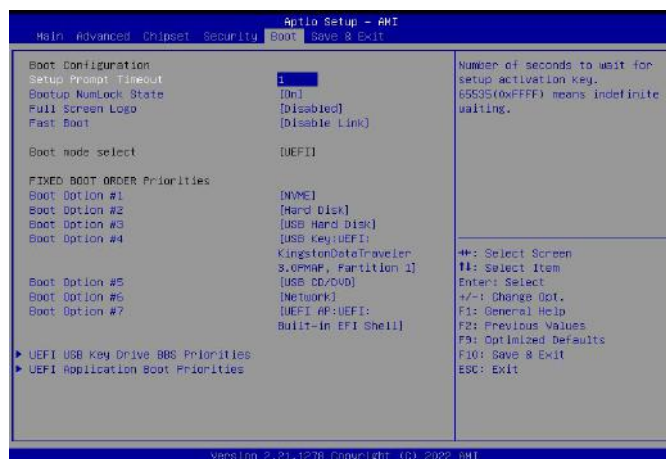

- **Setup Prompt Timeout**

Set the time of stay on the power-on screen.

- **Bootup NumLock State**

Set the Numlock state after the system is started. When set to On, NumLock will be enabled and

the number keys on the small keyboard will be valid after the system is started. When set to Off, NumLock will be disabled and the direction keys on the small keyboard will be valid after the system is started.

Options: On, Off.

- **Full Screen Logo**

Full screen logo display switch.

Options: Enabled, Disabled.

- **Fast Boot**

Set the fast boot function.

Options: Enabled, Disabled Link.

- **Boot mode select**

It allows to select the boot device with priority, and the devices displayed on the screen depend on that installed on the system.

Options: LEGACY, UEFI.

- **Boot Option #1-7**

Set the boot sequence of system.

Options: NVME, Hard Disk, USB Hard Disk, USB key, USB CD/DVD, Network, UEFI AP: Built-in EFI Shell.

## 4.8 Save & Exit



- **Save Changes and Reset**

Save the changes and reboot the system.

- **Discard Changes and Reset**

Discard the changes and reboot the system.

- **Restore Defaults**

Restore and load all option defaults.

## Chapter 5 Install driver

Please insert the motherboard driver disk into the CD-ROM drive, the driver disk will run automatically and then a pop-up interface will appear as shown below. If this interface does not appear, please double click to run X: \AUTORUN. EXE (assuming the symbol of driver disk is X: ).

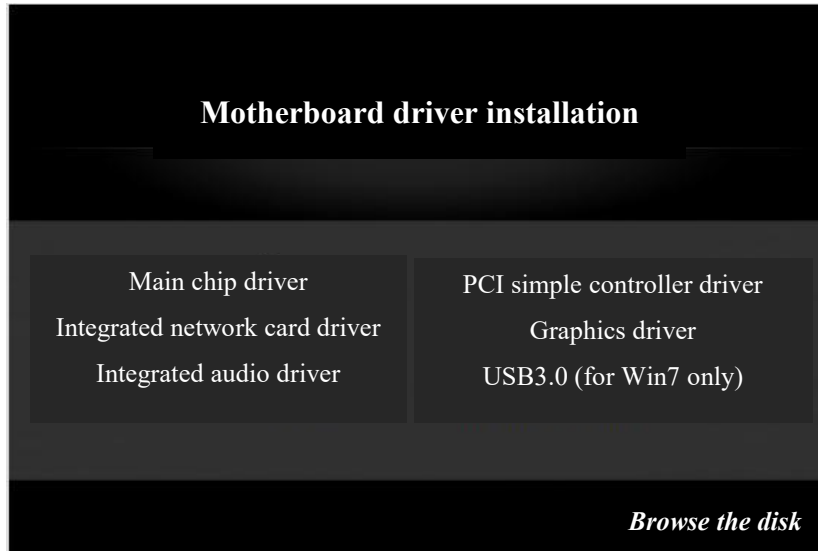

(This image is for reference only, please prevail in kind)

Please click the drivers you need to install in the above interface in turn, and follow the prompts to install them.

## Chapter 6 WDT programming guide

### 6.1 WDT control

WDT control registers are located in LDN DEV8 of the SIO chip, where 0XF0 BIT3 refers to the control by second and minute, 0 represents second and 1 represents minute, 0XF1 is filled with the time. For example, 0XF0 BIT3 is 0, and 0XF1 is filled with 0X20, representing the overflow time of 32 seconds.

#### 6.1.1 The pseudo-code of Watch Dog is set as follows:

```
// Enter SIO control
IoWrite8 (0x2E,0x87);
IoWrite8 (0x2E,0x87);

IoWrite8 (0x2E,0x07);
IoWrite8 (0x2F,0x08)l // Select Logic Device 8

IoWrite8 (0x2E,0x30);
Data8 = IoRead8 (0x2F);
Data8 |= 0x1;
IoWrite8 (0x2F,Data8);

IoWrite8 (0x2E,0xf1);
IoWrite8 (0x2F,0x00);

IoWrite8 (0x2E,0xf2);
IoWrite8 (0x2F,0x00);

IoWrite8 (0x2E,0xF0);
Data8 = IoRead8 (0x2F);
//WdtCountMode=1 Select the unit of minutes
if (SetupData.WdtCountMode == 1){
Data8 = Data8 | 0x08;
}
else{
Data8 = Data8 & (~0x08);
}

IoWrite8 (0x2F,Data8);
IoWrite8 (0x2E,0xF1);
//WDT Overflow time
IoWrite8 (0x2F,SetupData.WdtTimeOut);
// Exit SIO control
IoWrite8 (0x2E,0xaa);
```

### 6.1.2 Clear watch dog

```
// Enter SIO control
IoWrite8 (0x2E,0x87);
IoWrite8 (0x2E,0x87);

IoWrite8 (0x2E,0x07);
IoWrite8 (0x2F,0x08)l // Select Logic Device 8

IoWrite8 (0x2E,0x30);
Data8 = IoRead8 (0x2F);
Data8 &= (~0x1);
IoWrite8 (0x2F,Data8);

IoWrite8 (0x2E,0xf1);
IoWrite8 (0x2F,0x00);
// Exit SIO control
IoWrite8 (0x2E,0xaa);
```

### CR F0h. Watchdog Timer I(WDT1) and KBC P20 Control Mode Register

Location: Address F0h

Attribute: Read/Write

Power Well: VSB

Reset by: LRESET# or PWROK

Default : 00h

Size: 8 bits

点击编辑文档  
支持编辑PDF文档文本、图片

BIT	READ / WRITE	DESCRIPTION
7-4	Reserved	
3	R / W	Select Watchdog Timer I count mode. 0: Second Mode. 1: Minute Mode.
2	R / W	Enable the rising edge of a KBC reset (P20) to issue a time-out event. 0: Disable. 1: Enable.
1	R / W	Disable / Enable the Watchdog Timer I output low pulse to the KBRST# pin (PIN15) 0: Disable. 1: Enable.
0	R / W	Watchdog Timer I Pulse or Level mode select 0: Pulse mode 1: Level mode

**CR F1h. Watchdog Timer I(WDT1) Counter Register**

Location: Address F1h

Attribute: Read/Write

Power Well: VSB

Reset by: LRESET# or PWROK

Default : 00h

Size: 8 bits

BIT	READ / WRITE	DESCRIPTION
7-0	R / W	Watch Dog Timer I Time-out value. Writing a non-zero value to the register causes the counter to load the value into the Watch Dog Counter and start counting down. The accuracy of watchdog timer I about one cycle deviation. If CR F2h, bits 7 and 6 are set, any Interrupt event comes from Mouse or Keyboard both cause the previously-loaded. Non-zero value will be reloaded to the Watch Dog Counter and the countdown resumes. Reading the register returns the current value in the Watch Dog Counter but not the Watch Dog Timer Time-out value. 00h: Time-out Disable 01h: Time-out occurs after one cycle time, the cycle time is based on LD8 CRF0, bit[3], by analogy.

# Chapter 7 GPIO programming guide

## 7.1 GPIO control

The hardware uses the GPIO pins with FINTEK 7511 expansion, the pins corresponding to 7511 are shown in the blow figure, and the communication is subject to PCHSMBUS control based on FINTEK 7511.

### 7.1.1 FINTEK 7511 SPEC (see the attached document):



F75111\_V027P.p  
df

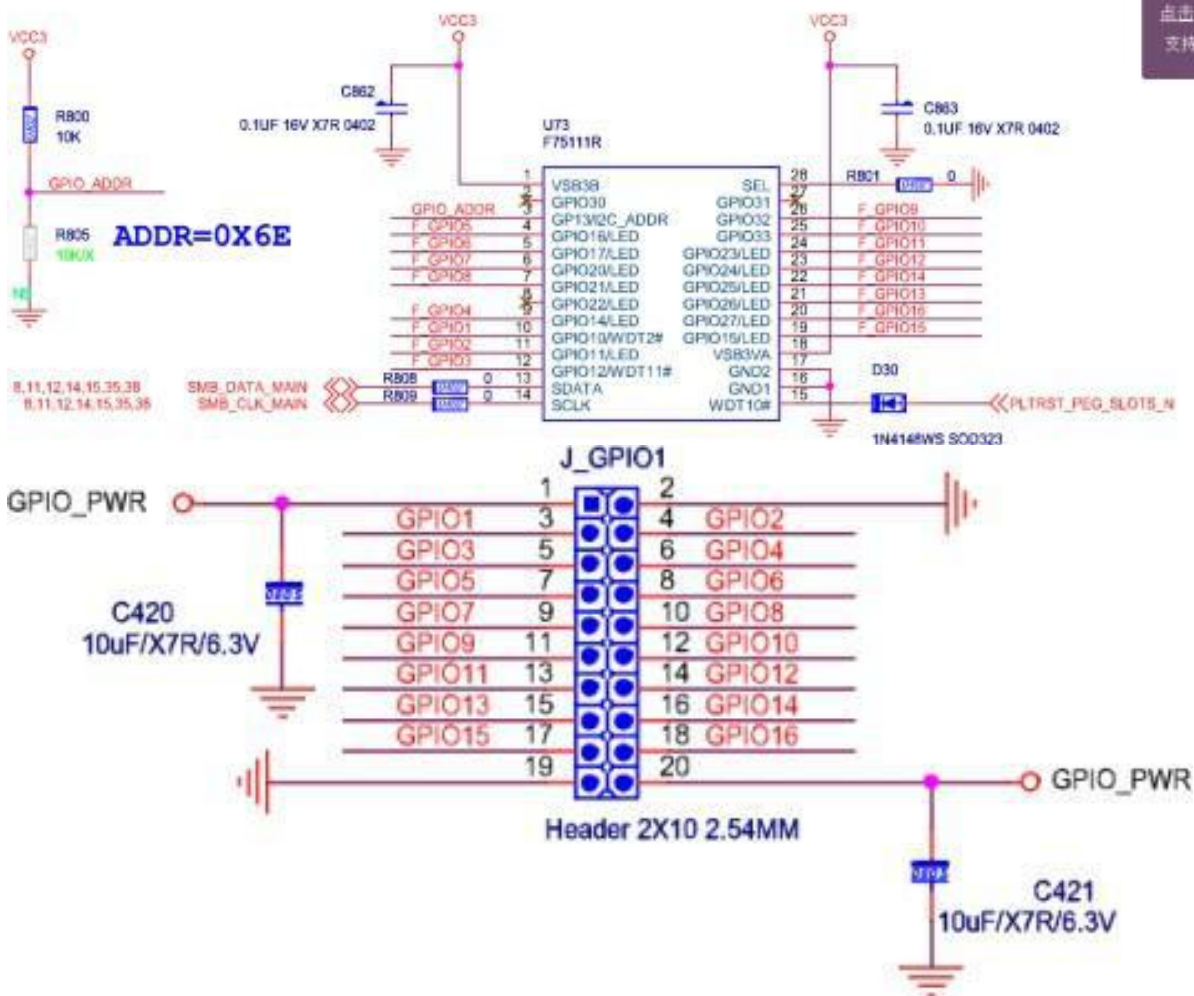



## Order information

Product model	Chipset	Memory	Display	Storage	USB3	USB2	COM	LAN	PCI	PCIe
AIoT9-H510	H510	2DDR4	4(2)	4SATA	4	6	6	2	2PCI	2PCIe
AIoT9-H510B	B560	4DDR4	4(3)	4SATA	6	6	6	3	2PCI	2PCIe



According to the requirements of SJ/T11364-2014 *Measures for the Control of Pollution from Electronic Information Products* issued by the Ministry of Information Industry of the People's Republic of China, the marking for the pollution control of this product and the marking for toxic and harmful substances or elements in this product are as follows:

**Marking for toxic and harmful substances or elements in this product:**

**Name and content of toxic and harmful substances or elements in this product**

Part Name	Toxic and harmful substances or elements					
	Pb	Hg	Cd	Cr (VI)	PBB	PBDE
PCB board	X	O	O	O	O	O
Structural part	O	O	O	O	O	O
Chip	O	O	O	O	O	O
Connector	O	O	O	O	O	O
Passive electronic parts and components	X	O	O	O	O	O
Welded metal	X	O	O	O	O	O
Wire rod	O	O	O	O	O	O
Other consumables	O	O	O	O	O	O

O: It means that the content of this toxic and harmful substance in all homogeneous materials of this part is below the limit requirement specified in GB/T 26572.  
X: It means that the content of this toxic and harmful substance in all homogeneous materials of this part exceeds the limit requirement specified in GB/T 26572.  
Note: The lead content at position X exceeds the limit specified by GB/T 26572, but complies with the exemption clause of the EU RoHS directive.